

- Air-operated, rated for high-duty-cycle (no rest periods required) and high load applications. The A40S features a higher capacity motor, higher torque gearbox and wide drive roller and support roller for improved load distribution traction.
- Features PowerHandling’s patented Direct-Drive (motor enclosed inside the drive roller) design using a rotary vane air motor with heavy duty three-stage planetary gearbox.
- Incorporates a heavy-duty, all-welded, reinforced and chrome-plated main chassis (not bolt-together) that features large diameter (100mm/4”) rear wheels for faster and easier maneuvering.
- All A-Series feature a swiveling “S” handle design allowing “separating” of rolls as well as a pivoting rear axle that allows the handle to be rotated forward to “pull” rolls/reels back toward the operator.
- Optionally a center (“C”) straight handle can be specified instead of the “S” handle.

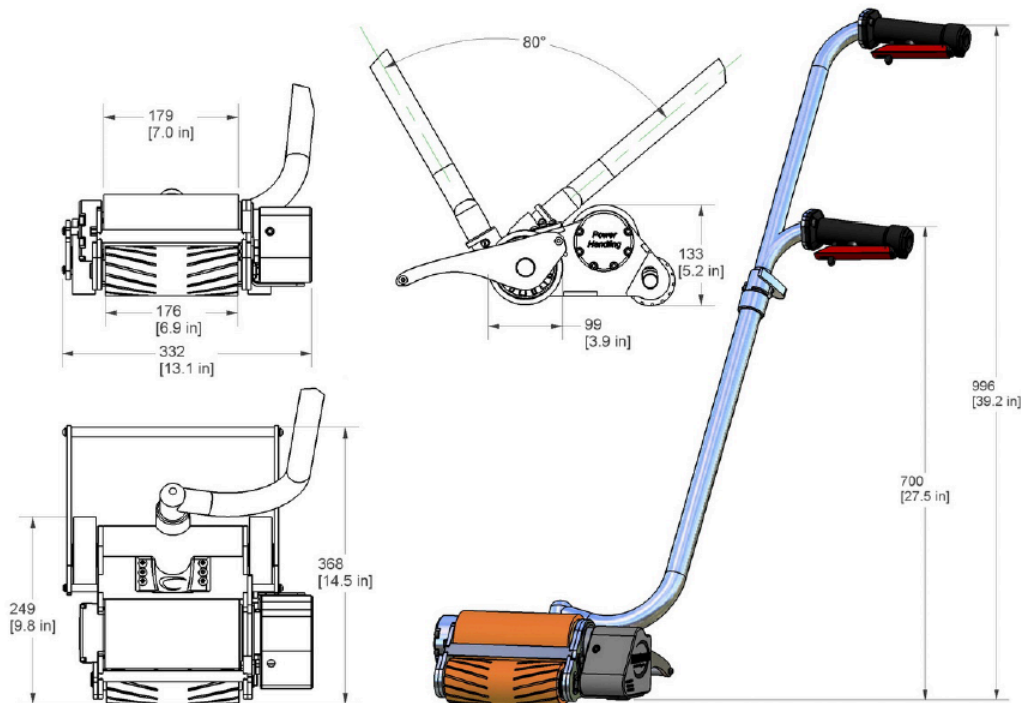

AIR MODELS	Estimated Maximum Load			Speed Unloaded	Duty-Cycle Capability	Req'd Air Pressure	Req'd Air Volume	Hose & Fittings Inside Diameter
	Cable, Flat	Paper, Flat	Paper, Lift					
	Metric Tonnes (Pounds)			m/min (ft/min)	(Low-High)	Bar (PSI)	lpm (cfm)	mm (inches)
A40S	19.4 (42,700)	10.2 (22,400)	7.3 (16,000)	15 (49)	High	7-8	1,500	12-15mm
A60S	28.1 (62,000)	14.8 (32,500)	10.6 (23,200)	10 (34)	High	(101-116)	(53)	(1/2"-5/8")